



FINGER FOOD

INDUSTRY



*Meeting the Finger Foods packaging challenge
- The Bilwinco Way*



www.bilwinco.com



FINGER FOODS

WRAPS

Challenges

- Precision in the placement of the different ingredients is paramount. Each recipe is different – flexibility at distribution tool level very important. Must be able to handle sticky ingredients well. Frequent product and ingredient changeovers require fast changeover times and easy cleanability.

Solution

- We custom-build the distribution tools for each application so that you can be certain that the filling is placed exactly where you need it, every time. Our distribution tools are quick to replace, to ensure your production flexibility during the often very changeable working days in the wraps/finger foods industry. The new Linear Drive radial feeders on our Revolution Series multihead weighers can handle any product gently yet efficiently, and our new design is sleek and clean like no other multihead weigher available today, making periodic cleansing and product changeover cleaning of the line a breeze.



Bilwinco tortilla conveyor securing full ingredient placement control

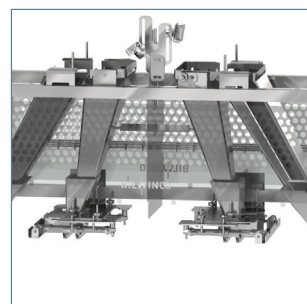

An example of a custom designed Bilwinco ingredient distribution tool

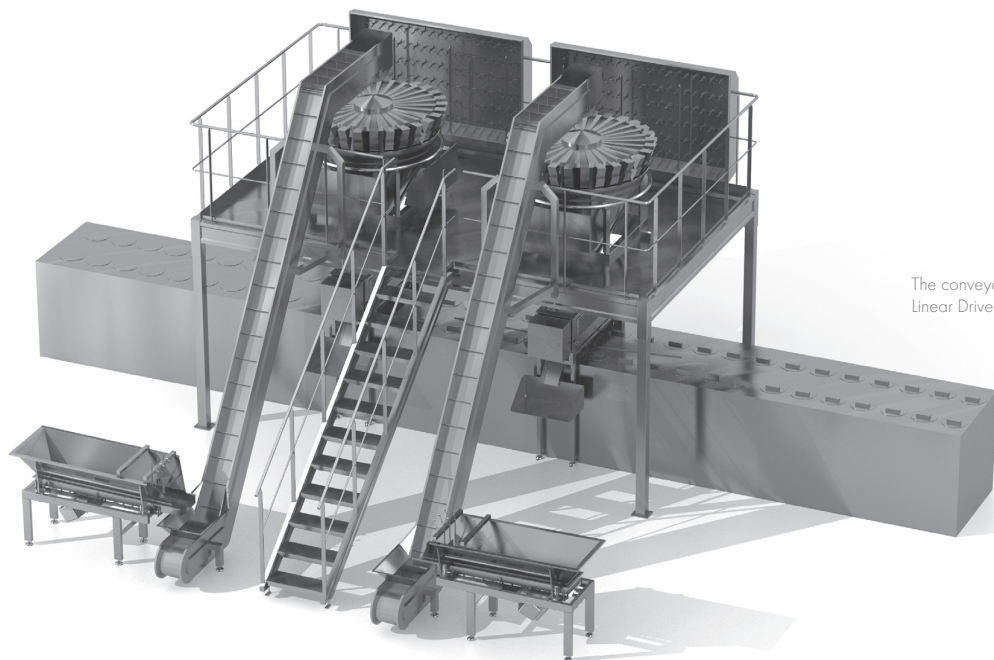

The conveyor loading the Linear Drive radial feeders



- 1) Tortilla conveyor
- 2) Storage hoppers
- 3) Infeed conveyor
- 4) Multihead weighers
- 5) Ingredient distribution tool
- 6) Platform with washing stations

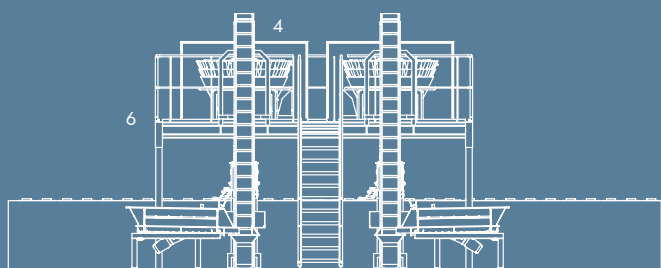

PIE & SANDWICH TOPPINGS

Challenges

Placement. As a manufacturer of pies or sandwiches you need to know for sure that each portion is placed exactly where you want it. Toppings can be many things, including sticky, wet or fragile ingredients. The weigher must be able to handle all of these with ease.

Changeover times. Hardly a pie or a sandwich line packs one product exclusively – frequent product changeovers are the norm, and the line must be quickly adaptable to new production runs.

Cleaning. All food industry is hygiene sensitive, with periodic cleaning and changeover cleaning often taking place several times a day

Solution

We tailor-make the distribution tools for each of your applications, and our tools are renowned for their placement accuracy. They are also extremely quick and easy to exchange whenever the production changes.

Our new Revolution Series multihead weighers are the only ones in the market that excel with sticky, difficult ingredients; they handle boiled shrimp as well as shredded cheese! And when it comes to cleaning no other manufacturer can match our cleanability – we have eliminated the recesses where debris may accumulate, we have made the whole unit waterproof to IP67 standards so you can use steam cleaning, and every component is optimised for cleanability.

Tests have shown that cleaning times can be reduced by up to 50% with our new weighers. If you opt for a mobile solution you increase your production flexibility even more, plus you get the added cleaning benefit of the ability to take the weigher offline for thorough cleansing.

Bilwinco Revolution Series multihead weighers are purpose-built for frequent changeovers, with their superior hygiene and cleanability compared to prevailing designs. Our weighers can be delivered with internal surfaces optimised for your products. And with the BWV Revolution Series even the most difficult and/or sticky product will be moving along at top speed.

Bilwinco custom-made distribution tool with reject function

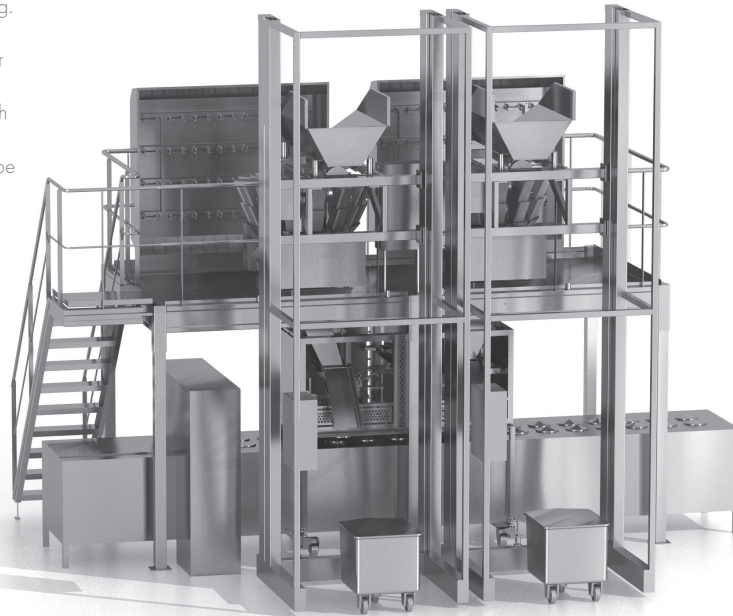

- 1) Dough conveyor
- 2) Pie dough forming unit
- 3) Product lifts
- 4) Forward vibrator
- 5) Multihead weigher
- 6) Ingredient distribution tool
- 7) Platform with washing stations

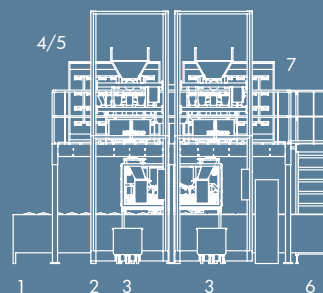

Bilwinco supplies complete packaging solutions for the Finger Foods industry. But we are more than a supplier of weighing and packaging solutions; we are your innovative business partner through every step of the process, from idea to operational packaging line.

Key arguments for a Bilwinco solution to your packaging needs:

- **LESS GIVEAWAY** – direct weighing ensures 20-30% less giveaway compared to traditional weighers
- **HIGHER CONSTANT THROUGHPUT** of difficult products with Linear Drive vibration (Patent pending), keeping productivity high and product quality unmatched
- **LOWEST COST OF OWNERSHIP(COO)** on the market



TURNKEY PACKAGING SOLUTIONS

At the heart of the matter lies our conviction that you know your products, and your markets, better than anyone else. Our task is simple; we listen, we observe and then we operationalise your knowledge, by building packaging lines matching your expectations. We call it the Bilwinco way.

OPERATIONALISING YOUR KNOWLEDGE

Our packaging lines consist of a custom-built Bilwinco weighing line combined with the packaging solution of your choice. Our strength is our intimate knowledge of the available packaging solutions, and how they interact with your product and our state-of-the-art multihead weighers. By choosing us as your turnkey contract supplier you eliminate many of the expensive variables inherent in the process. You define the task at hand once, to one partner, and we design the whole packaging line. Once the line is operational you have only one service number to call; ours.

G R E A S Y
S T I C K Y
F R A G I L E

The weigher is the pivotal unit in the multihead weigher packaging line. The speed and efficiency of the weigher defines the gross output of the entire line – and we are multihead weigher experts. The Bilwinco Revolution multihead weigher series is state-of-the-art technology from start to finish and the only weigher that excels with difficult and fragile foodstuffs. Practical tests have shown gross productivity increases of up to 10-15% compared to our competitors when processing difficult products. The improvements are accomplished through refinements of every step of the operational process, not least the improved hygiene, which in itself amounts to up to 50% less downtime for cleaning during product changeovers – particularly important in hygiene-sensitive industries such as finger foods.



Bilwinco has been a market leader in the weighing and packaging industry since 1955. At our company headquarters in Hjørring, Denmark, we develop and build individual solutions for our customers worldwide. Our experience is your guarantee that a Bilwinco packaging solution is always tailored to your particular demands.

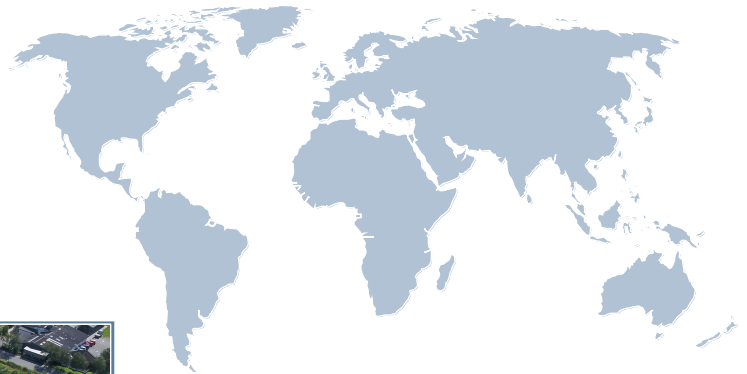

At Bilwinco we have people specialised in packaging solutions for the Finger Food industry. We are eager to begin the dialogue with you which will ultimately result in the perfect packaging line for your Finger Food products. May we suggest that you give us a call.



Bilwinco A/S
Hedevej 3
9800 Hjørring
Denmark
Tel: +45 86 51 06 66
Email: info@bilwinco.com
www.bilwinco.com

